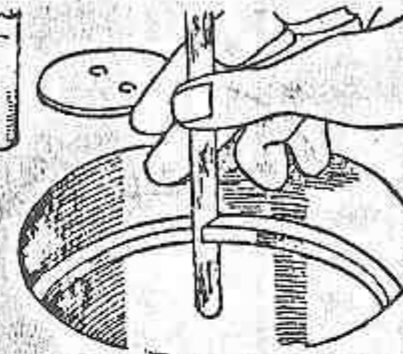
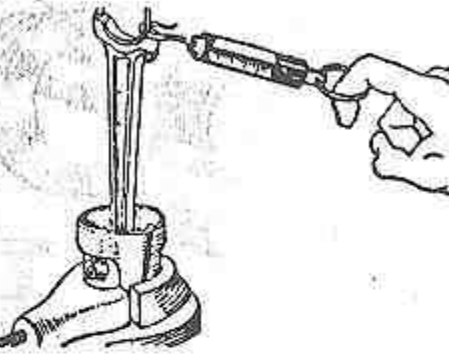
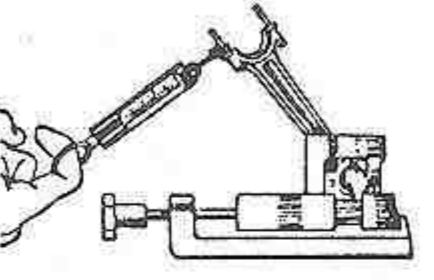
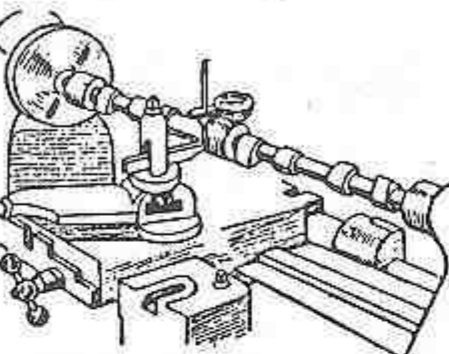
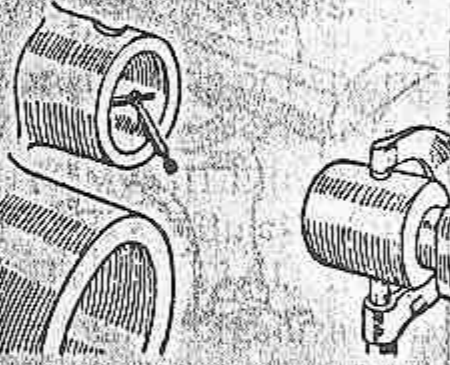
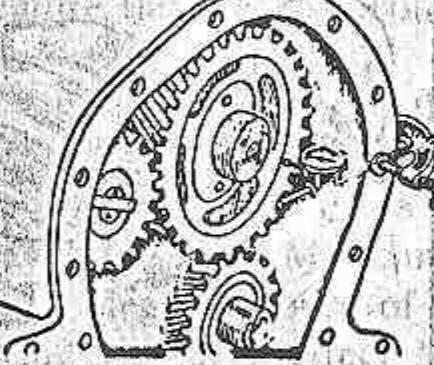
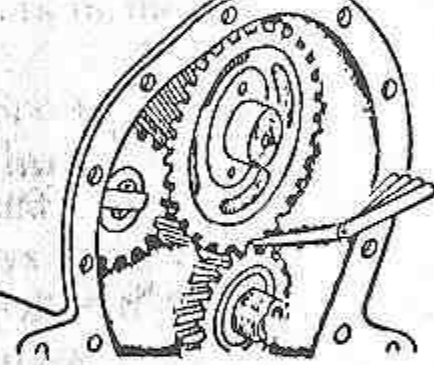
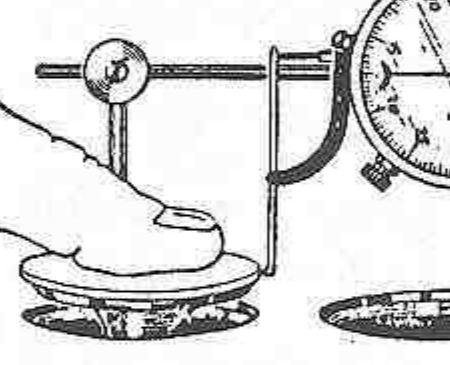
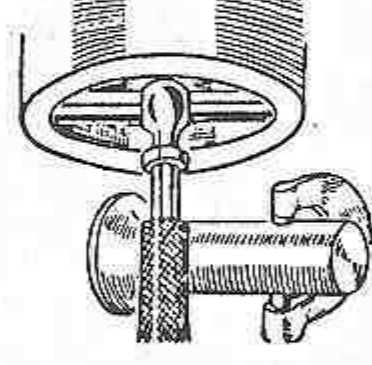
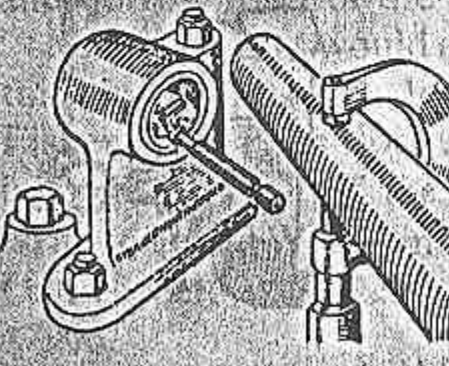
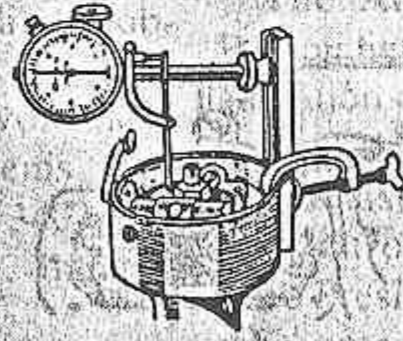
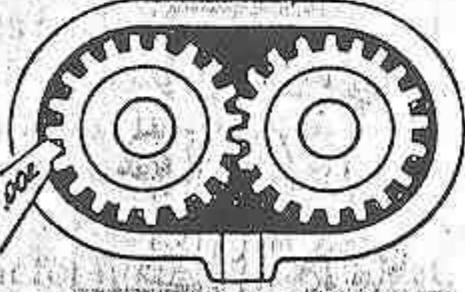
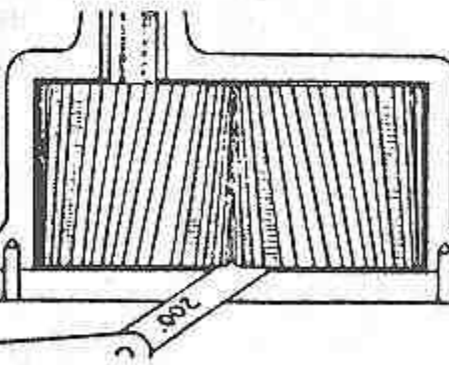
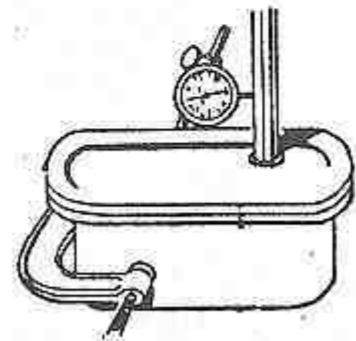
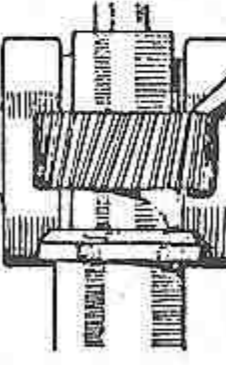

CLEARANCE STANDARDS

These tolerances are for general use only when the specific instructions of the manufacturer are not available.
Measurements in inches unless otherwise specified.

 <p>Measure clearance of piston rings in grooves with feeler gage. Desirable001-.0015 Serviceable0025 Repair or replace004</p>	 <p>Measure clearance between ends of rings in cylinders (clearance per inch of piston diameter). Desirable003 Serviceable004 Repair or replace006</p>	 <p>Measure fit of floating pin in alloy piston with spring scale. Desirable . . . 5-7 lb. pull when cold Serviceable when worn001 Repair or replace when worn .002</p>	 <p>Measure fit of pin using bronze bushings with spring scale. Desirable . . . 3-5 lb. pull when cold Serviceable when worn001 Repair or replace when worn .002</p>	 <p>Measure straightness of camshaft with dial gage. Desirable0005-.001 Serviceable002 Repair or replace004</p>	
 <p>Measure camshaft bearing to journal clearance with micrometer calipers and telescoping gage. Desirable001-.002 Serviceable003 Repair or replace005</p>	 <p>Measure lateral trueness of camshaft timing gear with dial gage. Desirable001-.002 Serviceable003 Repair or replace005</p>	 <p>Measure clearance between teeth on camshaft and crankshaft timing gears with feeler gage. Desirable001-.002 Serviceable004 Repair or replace006</p>	 <p>Measure clearance between valve stem and valve guide with dial gage. Desirable002-.004 Serviceable005 Repair or replace006</p>	 <p>Measure clearance between valve lifter and lifter guide with micrometer calipers and telescoping gage. Desirable001-.002 Serviceable003 Repair or replace005</p>	
 <p>Measure clearance between rocker arm shaft and bushings with micrometer calipers and telescoping gage. Desirable001-.002 Serviceable003 Repair or replace005</p>	 <p>Measure sidewise movement of ignition distributor cam with dial gage. Desirable001-.002 Serviceable004 Repair or replace006</p>	 <p>Measure clearance between oil pump gear teeth and housing with feeler gage. Desirable001-.002 Serviceable004 Repair or replace006</p>	 <p>Measure clearance between oil pump housing cover and face of gears with feeler gage. Desirable001-.002 Serviceable004 Repair or replace006</p>	 <p>Measure clearance between oil pump shaft and bushings with dial gage. Desirable001-.002 Serviceable004 Repair or replace006</p>	 <p>Measure clearance between oil pump drive gear and camshaft gear teeth with feeler gage. Desirable003-.005 Serviceable007 Repair or replace010</p>

Continued

CLEARANCE STANDARDS

These tolerances are for general use only when the specific instructions of the manufacturer are not available.
Measurements in inches unless otherwise specified.

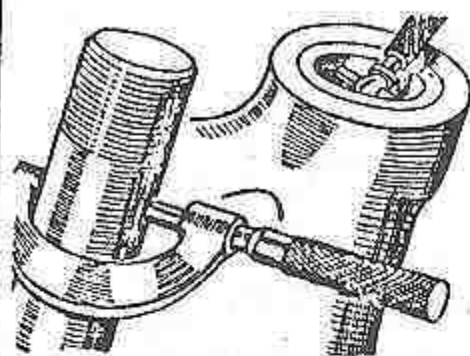
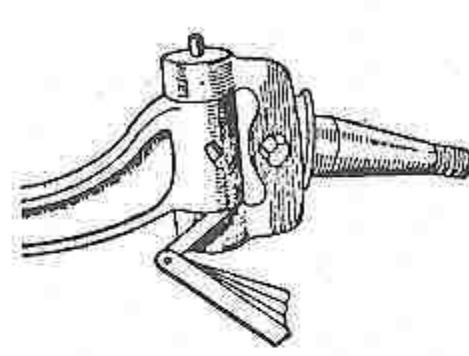
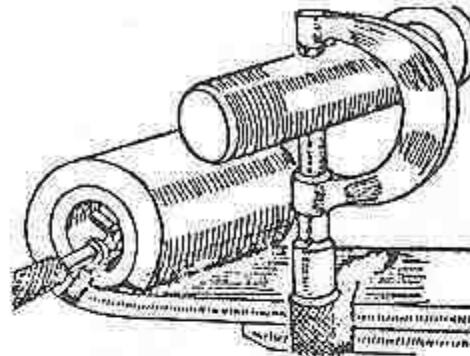
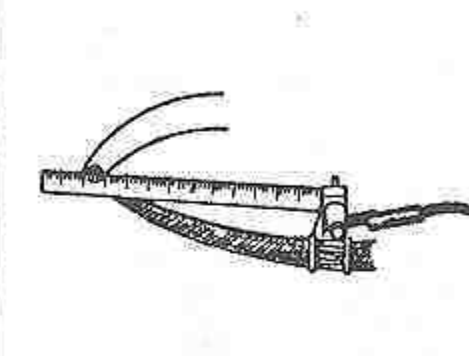
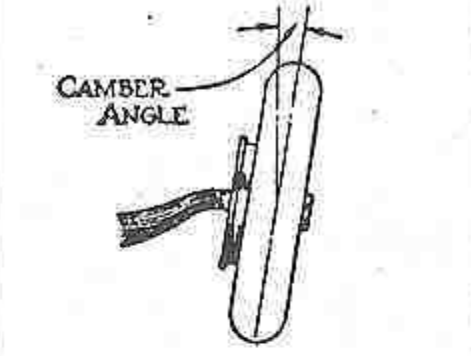
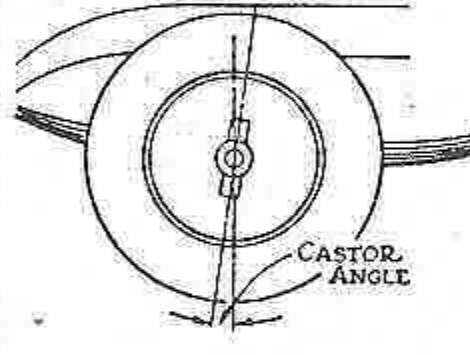
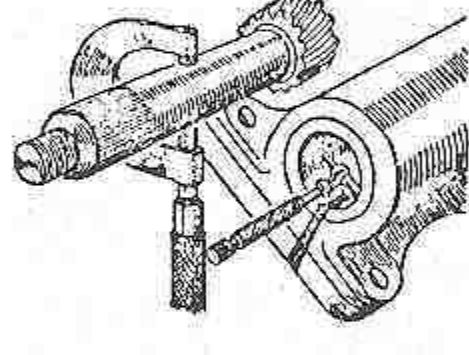
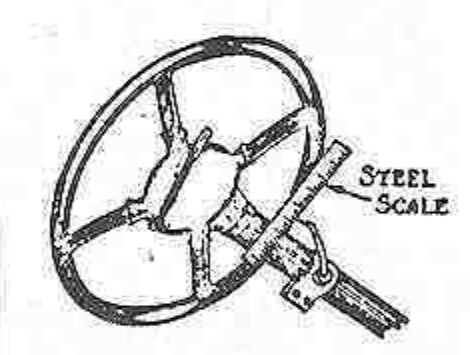
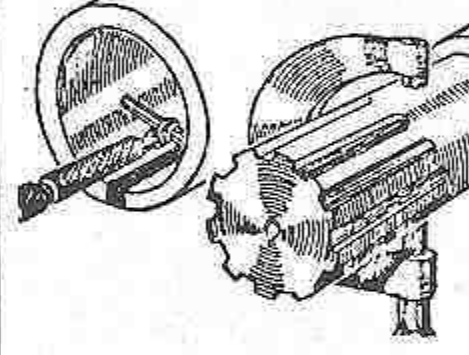
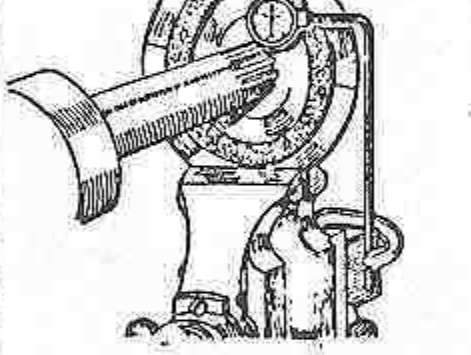
 <p>Measure king pin clearance in bushing with micrometer calipers and telescoping gage.</p> <table border="0"> <tr><td>Desirable</td><td>.....</td><td>.001-.002</td></tr> <tr><td>Serviceable</td><td>.....</td><td>.005</td></tr> <tr><td>Repair or replace</td><td>.....</td><td>.007</td></tr> </table>	Desirable001-.002	Serviceable005	Repair or replace007	 <p>Measure end clearance of spindle thrust bearings with feeler gage.</p> <table border="0"> <tr><td>Desirable</td><td>.....</td><td>.010</td></tr> <tr><td>Serviceable</td><td>.....</td><td>.015-.025</td></tr> <tr><td>Repair or replace</td><td>.....</td><td>.030</td></tr> </table>	Desirable010	Serviceable015-.025	Repair or replace030	 <p>Measure clearance between spring eye bolt and bushing with micrometer calipers and telescoping gage.</p> <table border="0"> <tr><td>Desirable</td><td>.....</td><td>.001-.002</td></tr> <tr><td>Serviceable</td><td>.....</td><td>.010</td></tr> <tr><td>Repair or replace</td><td>.....</td><td>.015</td></tr> </table>	Desirable001-.002	Serviceable010	Repair or replace015	 <p>Measure variation in distance between spring eye bolt and axle on each side with steel scale.</p> <table border="0"> <tr><td>Desirable</td><td>.....</td><td>1/64</td></tr> <tr><td>Serviceable</td><td>.....</td><td>1/32</td></tr> <tr><td>Repair</td><td>.....</td><td>1/16</td></tr> </table>	Desirable	1/64	Serviceable	1/32	Repair	1/16	 <p>Measure variation in camber of front wheels on each side with camber gage.</p> <table border="0"> <thead> <tr> <th></th> <th>DEGREES</th> <th>INCHES</th> </tr> </thead> <tbody> <tr><td>Desirable</td><td>..... 0</td><td>1/32</td></tr> <tr><td>Serviceable</td><td>..... 1/4</td><td>1/16</td></tr> <tr><td>Repair</td><td>..... 1/2</td><td>1/8</td></tr> </tbody> </table>		DEGREES	INCHES	Desirable 0	1/32	Serviceable 1/4	1/16	Repair 1/2	1/8
Desirable001-.002																																																		
Serviceable005																																																		
Repair or replace007																																																		
Desirable010																																																		
Serviceable015-.025																																																		
Repair or replace030																																																		
Desirable001-.002																																																		
Serviceable010																																																		
Repair or replace015																																																		
Desirable	1/64																																																		
Serviceable	1/32																																																		
Repair	1/16																																																		
	DEGREES	INCHES																																																		
Desirable 0	1/32																																																		
Serviceable 1/4	1/16																																																		
Repair 1/2	1/8																																																		
 <p>Measure castor of front axle with castor gage, (variation from specifications).</p> <table border="0"> <thead> <tr> <th></th> <th>DEGREES</th> </tr> </thead> <tbody> <tr><td>Desirable</td><td>..... 0</td></tr> <tr><td>Serviceable</td><td>..... 1/4</td></tr> <tr><td>Repair</td><td>..... 1/2</td></tr> </tbody> </table>		DEGREES	Desirable 0	Serviceable 1/4	Repair 1/2	 <p>Measure clearance between pitman arm shaft and bushing with micrometer calipers and telescoping gage.</p> <table border="0"> <tr><td>Desirable</td><td>.....</td><td>.001-.002</td></tr> <tr><td>Serviceable</td><td>.....</td><td>.004</td></tr> <tr><td>Repair or replace</td><td>.....</td><td>.006</td></tr> </table>	Desirable001-.002	Serviceable004	Repair or replace006	 <p>Measure looseness of steering gear at rim of wheel with pointer and steel scale.</p> <table border="0"> <tr><td>Desirable</td><td>.....</td><td>1/4-1 in.</td></tr> <tr><td>Serviceable</td><td>.....</td><td>2 in.</td></tr> <tr><td>Repair</td><td>.....</td><td>3 in.</td></tr> </table>	Desirable	1/4-1 in.	Serviceable	2 in.	Repair	3 in.	 <p>Measure clearance between sliding sleeve and clutch shaft with micrometer calipers and telescoping gage.</p> <table border="0"> <tr><td>Desirable</td><td>.....</td><td>.001-.002</td></tr> <tr><td>Serviceable</td><td>.....</td><td>.005</td></tr> <tr><td>Repair or replace</td><td>.....</td><td>.007</td></tr> </table>	Desirable001-.002	Serviceable005	Repair or replace007	 <p>Measure clearance between clutch hub and clutch shaft splines with dial gage.</p> <table border="0"> <tr><td>Desirable</td><td>.....</td><td>.002-.003</td></tr> <tr><td>Serviceable</td><td>.....</td><td>.006</td></tr> <tr><td>Repair or replace</td><td>.....</td><td>.010</td></tr> </table>	Desirable002-.003	Serviceable006	Repair or replace010				
	DEGREES																																																			
Desirable 0																																																			
Serviceable 1/4																																																			
Repair 1/2																																																			
Desirable001-.002																																																		
Serviceable004																																																		
Repair or replace006																																																		
Desirable	1/4-1 in.																																																		
Serviceable	2 in.																																																		
Repair	3 in.																																																		
Desirable001-.002																																																		
Serviceable005																																																		
Repair or replace007																																																		
Desirable002-.003																																																		
Serviceable006																																																		
Repair or replace010																																																		

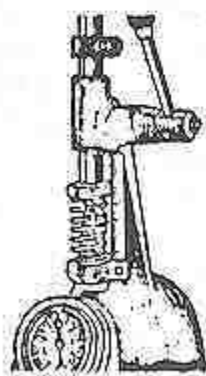

Measure difference in pressure between clutch springs with spring pressure testing gage.

Desirable	1-2 lb.
Serviceable	3 lb.
Replace	5 lb.

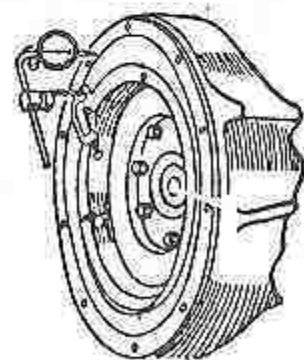

Measure alignment of clutch bell housing with flywheel face, using dial gage.

Desirable002-.003
Serviceable005
Repair or replace010

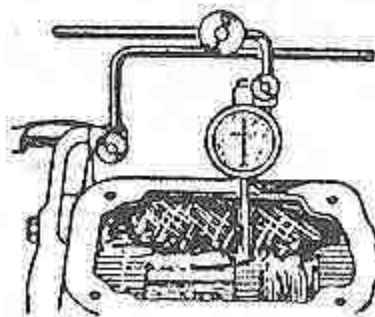

Measure clearance between transmission gear teeth with dial gage.

Desirable003-.005
Serviceable012
Repair or replace015

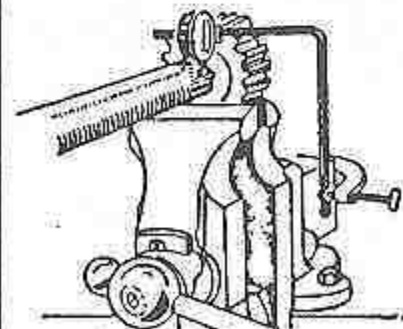

Measure clearance between gear hub and splines of shaft with dial gage.

Desirable001-.002
Serviceable004
Repair or replace005

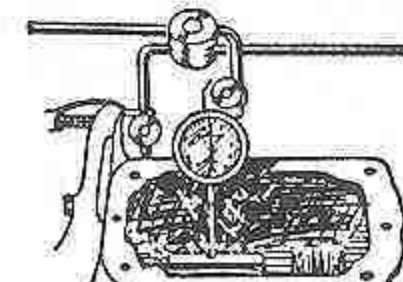

Measure diametral clearance of transmission bearings with dial gage.

Desirable0005-.001
Serviceable004
Repair or replace005

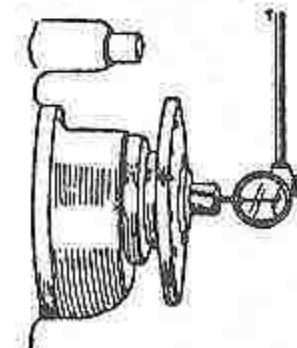

Measure end clearance of transmission bearings with dial gage.

Desirable001-.003
Serviceable005
Repair or replace010